

SENTINEL™

YOUR KEY TO NDT

MODEL 989 "Baby SCAR"

Radiographic Exposure
Device for Small Controlled
Area Radiography (SCAR)

- Uses ⁷⁵Se^{ntinel}™ (20 Ci Max)
- Directional Beam Device
- Small and Lightweight
- Tungsten and Lead Shielding
- Hand crank or pneumatic actuator operation.



QSA GLOBAL

MODEL 989 Exposure Device

APPLICATIONS FOR THE MODEL 989

SENTINEL™ Model 989 Gamma Radiography Exposure Device from QSA Global, Inc. performs directional beam gamma radiography of welds and the adjacent heat affected areas on pipelines and industrial structures. To carry out its task, the Model 989 contains a $^{75}\text{Se}^{\text{ntinel}}$ special form sealed source with a maximum activity of 20.0 Curies (740 GBq).

The Model 989 is specifically designed for Small Controlled Area Radiography

(SCAR), enabling safe radiography in areas congested with workers. Moreover, when compared to conventional crank-out radiography systems, the Model 989 significantly reduces the distances to “controlled” or “restricted” areas.

The basic radiography system consists of the Model 989 exposure device, a pneumatic actuator and remote pump control, and/or the optional crank-out remote controls and shielding materials that attenuates the primary beam after it passes through the specimen and film cassette.

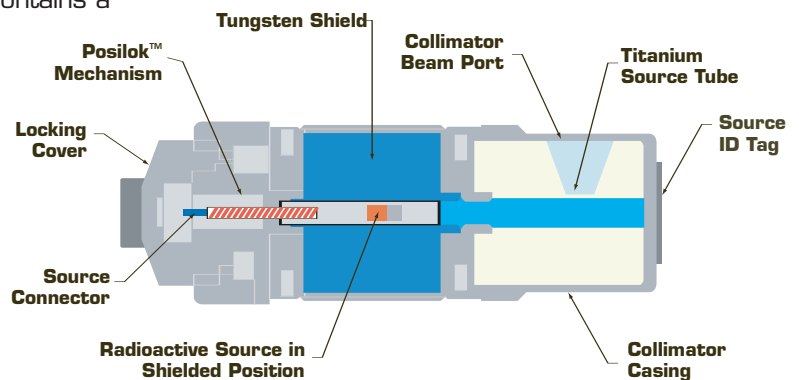

OPERATION AND CARE OF THE MODEL 989

The source assembly of the Model 989 is exposed by using either a pneumatic actuator or crank-out remote controls. Both expose the source assembly from a shielded position into the beam port inside the exposure device, which is collimated to a 40 by 40 degree emergent beam. Optional collimation is available upon request.

Once the radiographic exposure is completed, the source assembly is retracted to the fully shielded position by either exhausting the pneumatic actuator or using the mechanical remote controls to manually retract the source assembly.

A daily inspection of the exposure device for obvious defects is required. Complete annual servicing of the Model 989 and/or collimator replacement is also required, and should be performed by Sentinel™ or by one of its authorized service centers, and is typically done during source reloading.

Operating the Model 989 using the crank-out remote controls permits exposure of the sealed source, as well as automatic securing. Both are accomplished by cranking approximately 1/3 of a full revolution of the remote control hand crank.

When using the pneumatic actuator, the Model 989's lock-slide is pushed into the expose position, and remains in that setting until the actuator can be removed safely once the device's operation is concluded and the exposure is terminated.

SAFE STORAGE AND SHIPMENT

The Model 989 comes with a key-lockable protective cover and reusable lockable shipping case, which serves as the Type A storage and transport package for the radioactive source. The exposure device itself consists of a stainless steel housing, which contains a tungsten shield. This choice of material was made because when the source is in the storage position, the shielding properties of the tungsten reduce radiation intensities on the surface to levels that fall within regulatory limits.

RADIOACTIVE SOURCE ASSEMBLY

The SENTINEL™ source assembly Model 97941 is specifically designed and approved for use with SENTINEL's patented $^{75}\text{Se}^{\text{ntinel™}}$ sealed source.

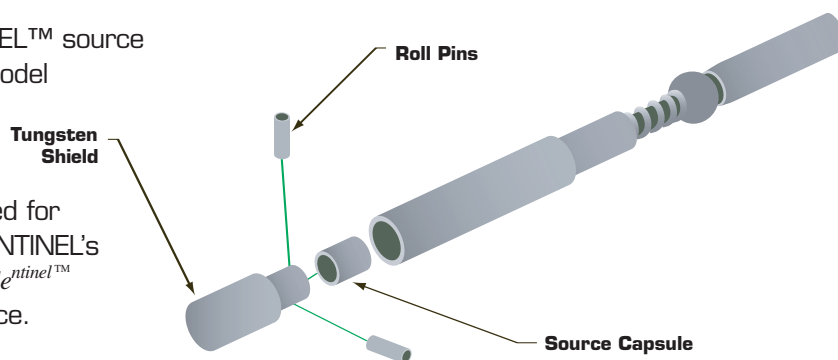

KEY FEATURES & BENEFITS OF MODEL 989

- It is a directional beam device, so there is no "open air" dose/rate during exposure and retraction modes. Its directional beam ensures that there is a smaller zone of influence during the exposure, permitting 24/7 operation.
- It is small and lightweight, which make it ideal for DW/SW or SW radiographic applications. Its small diameter allows it to be used in pipe racks and its light weight permits it to be mounted like a collimator.
- When using the optional pneumatic actuator, the sealed source will return to a "fail safe" position when air pressure is removed or exhausted
- When using the optional remote manual control the sealed source is secured by the Posilok™ (automatic securing mechanism) when returned to the fully shielded position.
- Upon request, specially designed fixtures and accessories are available to optimize the SCAR technique.

SENTINEL™

Sales

SENTINEL™
QSA Global, Inc.
6765 Langley Drive
Baton Rouge, Louisiana 70809 USA

Telephone: + 1 225 751 5893
Toll Free: + 1 800 225 1383
Fax: + 1 225 756 0365 or
+ 1 225 751 8082

Manufacturing

SENTINEL™
QSA Global, Inc.
40 North Avenue,
Burlington, Massachusetts 01803 USA

Telephone: + 1 781 272 2000
Toll Free: + 1 800 815 1383
Fax: + 1 781 273 2216

Email: sales@SENTINELNDT.com
Website: www.SENTINELNDT.com



All goods and services are sold subject to the terms and conditions of QSA Global, Inc. A copy of these terms and conditions is available upon request.

SENTINEL™ is a trademark of QSA Global, Inc.

POSILOK™ is a trademark of QSA Global, Inc.

All brand names and product names where used are acknowledged to be trademarks of their respective holders.

© 2010 QSA Global, Inc.

BRO-012 February 2010

Technical Specifications:

Primary application: Directional beam industrial gamma radiography

Model number: Model 989 radiographic exposure device

Length: 7.9 inches (20.1cm) without storage cover

Diameter: The main body is 3.5 inches (8.9cm) diameter and the Posilok actuator protrudes .375 inches (1cm).

Mass: 16.0 pounds (7.3 kg) maximum

Shielding: 5.7 pounds (2.6 kg) of tungsten plus 3.8 to 5.4 pounds (1.7 to 2.5 kg) of lead or tungsten for the collimator

Construction: Tungsten shielding is encased in a welded tubular stainless steel shell. The collimator shielding contains lead or tungsten metal to shape the emergent primary beam when the source assembly is in the exposure position. The shell is partially sealed to prevent the ingress of mud, sand, moisture and liquids during use. The exposure device should not be submerged in liquids during use.

Device Mounting Provision: Manufactured with six 1/4-20 UNC thread mounting-holes, 1/2" deep, which permits secure attachment to positioning-fixtures.

Maximum capacities of the Model 989 exposure device: 20.0 Curies (740 GBq) of Selenium-75 as special form

Source assembly model number: Sentinel™ Model 97941

Sealed source capsule: Designed for Sentinel™ Model X540/1 only

Sealed source and exposure device certifications: Special form: USA/O502/S-96
The exposure device contained in the transport package meets the requirements for a Type A transport packages under IAEA TS-R-1 (1996), USNRC 10CFR71, USDOT 49CFR173, and was designed to meet the applicable specifications of ISO 3999:2004(E) for Category X exposure devices.

Inspection requirements: A daily inspection of the device for obvious defects is required. Complete annual servicing and/or collimator replacement can only be performed at Sentinel™ or at one of its authorized service centers.

Operating temperature range: -40 degrees F to 300 degrees F (-40 C to 149 degrees C)

Sentinel™ Model 989 actuators for radiographic exposures: The Model 989 exposure device is compatible for use with Sentinel manufactured crank-out remote controls or air pressure actuators (part number ELE O27). For designed radiological safety, the only crank-out remote controls and air pressure actuators that can be used with the exposure device must be authorized by Sentinel™.